



Product Specification

XL160 Series

160-Watt AC to DC

Power Supplies

703123 Rev. H9

Notices

N2Power™ and the *N2Power* logo are registered trademarks of Qualstar Corporation.

Copyright© 2004-2015 by Qualstar Corporation — All Rights Reserved

For warranty information refer to www.n2power.com

N2Power products are covered by U.S. Patent 6,163,139.

Information contained in this document is copyrighted by Qualstar Corporation and is intended for use by customers and prospective customers to evaluate and integrate our power supplies. Customers and prospective customers may reproduce this document as needed for these purposes. Reproduction in whole or in part for any other purpose or by any other party is prohibited without prior written permission from Qualstar Corporation.

Every effort has been made to keep the information contained in this document current and accurate as of the date of publication or revision. However, no guarantee is given or implied that the document is error-free or that it is accurate with regard to any specification.

Qualstar reserves the right to modify the design or specification without notice. This specification may not be construed as a contractual obligation except as specifically agreed to by *Qualstar* in writing at the time of order.

For information about this product specification, please write or call *Qualstar* at:

SMX POWER 3005 Avenida Simi, Simi Valley, CA 93063
TEL: (805) 582-2804 FAX: (805) 582-2308 <http://www.smxpower.com>

Table of Contents

1. Introduction	1-1
1.1 Introduction.....	1-1
1.2 Agency Compliance.....	1-2
2. AC Input	2-1
2.1 Input Line Requirements.....	2-1
2.2 Input Over Current Protection.....	2-1
2.3 Inrush Current Limiting.....	2-1
2.4 Low Input Voltage.....	2-1
2.5 Leakage Current.....	2-1
3. DC Outputs	3-1
3.1 Output Voltage Regulation.....	3-1
3.2 No Load Operation.....	3-2
3.3 Output Current/Power.....	3-2
3.4 Cooling.....	3-4
3.5 Output Ripple/Noise.....	3-5
3.6 Local and Remote Sensing.....	3-8
3.7 Parallel Operation.....	3-10
3.8 Output Protection.....	3-11
3.9 Output Rise Time.....	3-12
3.10 Overshoot At Turn On/Turn Off.....	3-12
3.11 Output Transients.....	3-13
3.12 Closed Loop Stability.....	3-13
3.13 Capacitive Loading.....	3-13
4. General Specifications	4-1
4.1 Environmental.....	4-1
4.2 Mean Time Between Failures.....	4-1
4.3 Component Stress.....	4-1
4.4 Labeling/Marking.....	4-2
4.5 Weight.....	4-2
4.6 Mounting.....	4-2
4.7 Physical Dimensions.....	4-3
4.8 Mating Connectors.....	4-3
4.9 Output Grounding.....	4-6
4.10 Signal Pin Definitions.....	4-7
5. Efficiency	5-1
6. Timing and Control	6-1
6.1 Power Supply Timing.....	6-1

6.2	Power Good Signal/PS_OK Signal/Remote ON Input	6-1
6.3	Power Good LED	6-2
6.4	Power Sequencing: XL160-1[ATX] and XL160-7[ATX]	6-2
6.5	Voltage Hold-Up Time	6-2
7.	Ordering Information.....	7-1

1.1 Introduction

This specification defines the design and performance characteristics of an open frame single-phase (3 wire) universal input, power factor corrected, single or multiple output, 160-watt open frame switch mode power supply. It includes information regarding the mechanical details, cooling requirements, connector configurations, electrical and signal specifications, and environmental ranges for storage and operation of the power supply. It describes all AC-input XL160 models as listed in Table 3-1 and Table 7-1.

The XL160-1, XL160-7 and XL160-8 are multiple-output power supplies. They are also available with a 5-volt standby output and a remote enable input for the main outputs. These models meet the output requirements of Intel ATX/ATX12V Power Supply Design Guide (Version 2.03).

All models of the XL160 Series can be used as standalone power supplies while models XL160-05 CS through XL160-56 CS can also be used in redundant or N+1 configurations with up to 4 units connected in parallel. Lettering shown in square brackets indicate optional features or similar models (ex.: [CS] indicates that an active current-sharing feature is available on this model while [ATX] indicates this model is available with the +5V standby power option.) See Table 7-1 for a list of available options.



Figure 1 XL160 (models differ slightly)

1.2 Agency Compliance

Safety	Complies with Standard	Remarks
United States	UL 60950-1 (December 19, 2011) Second Edition (Information Technology Equipment)	Leakage Current – see table 2-2 Hi-pot – 2121vdc for 1 second
Canada	CAN/CSA-C22.2 No. 60950-1 (2007) Second Edition	
EU Council	2006/95/EC (August 2007)	Low Voltage Directive
International	IEC 60950-1 (2005) Second Edition	
China (CCC)	GB4943.1-2011	
Taiwan (BSMI)	CNS14336-1 (2010)	Selected models only
EMC	Complies with Standard	Remarks
United States	FCC part 15, subpart B	Conducted emissions Limits per CISPR 22 Class B Tested to ANSI C63.4: 2003
EU Council	2004/108/EC	EMC Directive
International	EN 61204-3 (refers to the following) EN 55022 Class B EN 55024 (refers to the following) EN 61000-3-2 Class D EN 61000-3-3 EN 61000-4-3 EN 61000-4-4 EN 61000-4-5 EN 61000-4-6 EN 61000-4-11	Low Voltage Power Supplies – DC Output Conducted emissions Limits per CISPR 22 Class B Immunity Harmonic Current Emissions (Power Factor Correction – PFC) Voltage Fluctuations & Flicker Radiated Susceptibility Fast Transient/Burst Immunity Power Mains Surge Immunity RF Immunity Voltage Dips, Short Interruptions
Reduction of Hazardous Substances (RoHS)	Complies with Standard	Remarks
EU Council	2002/95/EC 2011/65/EU	RoHS Directive RoHS 2 Directive

Continued below.

Marks of Conformance

United States & Canada

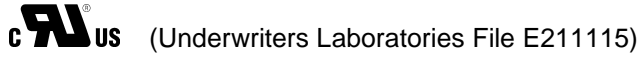

China

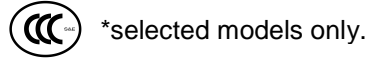

*Only associated with the CCC mark.
Only used at altitude not exceeding 2000M. ①



*Only associated with the CCC mark.
Only used in non-tropical climate regions.

Taiwan

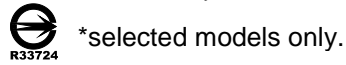

EU Council



RoHS



Table 1-1 Agency Compliance

2.1 Input Line Requirements

The following table defines the voltage and frequency requirements for the AC line inputs to the XL160 power supply. The XL160 is capable of supplying full rated power in continuous operation throughout the specified ranges of voltages and frequencies. The power supply will automatically recover from AC power loss and is capable of starting under maximum load at the minimum AC input voltage described below.

Parameter	Minimum	Nominal	Maximum
RMS Input Voltage	90 VAC	100–240 VAC	264 VAC
RMS Input Current	–	–	2.2 A @ 100 V 1.0 A @ 240 V
Input Frequency	47 Hz	50/60 Hz	63 Hz

Table 2-1 XL160 AC Input Parameters

2.2 Input Over Current Protection

The XL160 series incorporates a primary AC line fuse for input over current protection and to meet product safety requirements as outlined in Section 1.2.

2.3 Inrush Current Limiting

The cold start inrush current is limited to 33 A peak at 115 VAC. Repetitive ON/OFF cycling of the AC input voltage shall not damage the power supply or cause the input fuse to fail.

2.4 Low Input Voltage

The application of an input voltage below the minimums specified in Table 2-1 shall not cause damage to the power supply.

2.5 Leakage Current

The leakage current from AC line or AC Neutral inputs to Earth Ground at 240 VAC, 50Hz is less than 750 microamps.

3.

DC Outputs

3.1 Output Voltage Regulation

The DC output voltages shall remain within the Minimum and Maximum limits of Table 3-1 when measured at the power supply connector under all specified line, load and environmental conditions contained herein. The main output (V1) in the single output models (-12 thru -56V) and the 12-volt auxiliary outputs are both galvanic isolated from each other and chassis (Safety ground). Refer to Section 3.3.4.

Model	Output	Rated Voltage	Regulation	Minimum (VDC)	Nominal (VDC)	Maximum (VDC)	Remote Sense (① except ATX)
XL160-1	V1	+3.3	±3%	3.201	3.300	3.399	V1/RTN
	V2	+5	±4%	4.848	5.050	5.252	V2 ^② /RTN
	V3	+12	±5%	11.400	12.000	12.600	RTN
	V4	-12	±5%	-11.400	-12.000	-12.600	
ATX only	V5	+5V _{standby}	±5%	4.750	5.000	5.250	
XL160-7	V1	+2.5	±3%	2.425	2.500	2.575	V1/RTN
	V2	+5	±4%	4.848	5.050	5.252	V2 ^② /RTN
	V3	+12	±5%	11.400	12.000	12.600	RTN
	V4	-12	±5%	-11.400	-12.000	-12.600	
ATX only	V5	+5V _{standby}	±5%	4.750	5.000	5.250	
XL160-8	V1	none					
	V2	+5	±4%	4.848	5.050	5.252	V2 ^② /RTN
	V3	+12	±5%	11.400	12.000	12.600	RTN
	V4	-12	±5%	-11.400	-12.000	-12.600	
ATX only	V5	+5V _{standby}	±5%	4.750	5.000	5.250	
XL160-11 * with OR-ing diode	V1	+5.3*	±3%	5.141	5.300	5.459	V1/RTN
	V2	+12*	±5%	11.400	12.000	12.600	RTN
	V3	-12	±5%	-11.400	-12.000	-12.600	
XL160-XX CS XX: 05, 07, 08	V1	+5, +7, +8	±3%	Less 3%	5.00, 7.00, 8.00	Plus 3%	V1/RTN
	V2	+12V _{aux}	±5%	11.400	12.000	12.600	
XL160-XX [CS] 12 ≤ XX ≤ 56 See Table 7-1	V1	XX volts	±3%	Less 3%	XX.000	Plus 3%	V1/RTN
	V2	+/-12V _{aux}	±5%	11.400	12.000	12.600	
XL160-10	V1	5.6	±3%	5.432	5.600	5.768	V1/RTN
	V2	-5.8	±5%	-5.626	-5.800	-5.974	

Table 3-1 XL160 Output Voltage Specifications for all AC input Models

3.2 No Load Operation

The power supply will operate with reduced output voltage regulation of +/-10% with all outputs unloaded. This no load condition will not damage the XL160 or cause a hazardous condition, however the Power Good signal may not go true with less than a 5-watt load. The power supply will remain stable and operate normally after application of loads.

CAUTION

Remove AC power prior to installing or removing secondary loads.

3.3 Output Current/Power

The maximum available output power is always a function of the cooling airflow and temperature. The total output is reduced with unrestricted natural convection cooling and an ambient temperature of 50°C or less (see Sections 3.3.1 and 3.3.2). No output will exceed 240VA under any of overload or short circuit condition including single component fault conditions as described by IEC 60950.

3.3.1 Output Loading for Models XL160-1[ATX], -7[ATX], -8[ATX]

The maximum combined output power of V1 through V4 is limited to 160 watts with 10 CFM of forced air-cooling at no more than 50°C. The combined output power of V1 and V2 is further limited to 100 watts. The V5 output is limited to 5 watts under the same conditions (total of 165 watts possible) on the ATX versions.

Output	Remarks	Rated V1 Output	Minimum Load	Maximum Load	Maximum Watts/Output
V1	Not on -8[ATX]	+2.5 V / +3.3 V	0.0 A	15.0 A	37.5 / 49.5
V2		+5 V	1.0 A	20.0 A	100
V3		+12 V	0.0 A	6.0 A	72
V4		-12 V	0.0 A	1.0 A	12
V5	ATX versions	+5 V _{standby}	0.0 A	1.0 A	5

Table 3-2 XL160-1, -7, -8 and ATX versions: Individual Min/Max Load Currents

With unrestricted natural convection cooling (see Section 3.4), the maximum combined output power of V1 through V4 is limited to 70 watts while the +5V_{standby} output on the ATX versions is limited to 0.5A (total of 72.5 watts possible).

3.3.2 Output Loading for Models XL160-11

The maximum combined output power of V1 through V3 is limited to 160 watts with 10 CFM of forced air-cooling at no more than 50°C.

Output	Rated V1 Output	Minimum Load	Maximum Load	Maximum Watts/Output
V1	+5 V	1.0 A	20.0 A	100
V2	+12 V	0.0 A	6.0 A	72
V3	-12 V	0.0 A	1.0 A	12

Table 3-3 XL160-11 Individual Min/Max Load Currents

With unrestricted natural convection cooling (see Section 3.4), the maximum combined output power of V1 through V3 is limited to 70 watts.

3.3.3 Output Loading for Models XL160-10

The maximum combined output power of V1 and V2 is limited to 143 watts with 10 CFM of forced air-cooling at no more than 50°C. This is an exception to the 160-watt output of the other models in this specification.

Output	Rated V1 Output	Minimum Load	Maximum Load	Maximum Watts/Output
V1	+5.6 V	0.9 A	24.0 A	134
V2	-5.8 V	0.0 A	1.5 A	8.7

Table 3-4 XL160-10 Individual Min/Max Load Currents

With unrestricted natural convection cooling (see Section 3.4), the maximum combined output power of V1 through V3 is limited to 70 watts.

3.3.4 Output Loading for Models XL160-05 [CS] through XL160-56 [CS]

The output currents listed in this section require 10 CFM of forced air-cooling at no more than 50°C. The total output of 160-watts is reduced to 115-watts with unrestricted natural convection cooling (see Section 3.4) except for the XL160-05 thru XL160-08, which are reduced to 70-watts.

These single-output models (XL160-XX [CS] where [CS] means with or without current sharing) all have an auxiliary 12V output (V2, 12V AUX) that is typically used to drive a cooling fan. The load on this V2 output can vary from 0 to 1.0 amps and does not affect the Power Good or PS_OK signals. Its load power detracts from the 160-watts otherwise available to the V1 load. On the XL160-05 thru XL160-08 models, the negative side of the V2 output is connected to the common ground “DC RETURN”. The main output (V1) in the single output models (-12 thru -56V) and the 12-volt auxiliary outputs are both galvanic isolated from each other and chassis (Safety ground). Thus, they can be used as either a positive or negative supply.

The signals on J3: DC Return, Current Share, PG and PS_OK are all reference to the negative rail of the V1 Main output. Connecting the “+” voltage lead to ground or customer’s return will yield a negative voltage on the “-“ leads.

Model	Rated V1 Output	Minimum Power Good Load (5W) ①	Maximum Continuous Load ②
XL160-05 [CS]	5 V	1.00 A	32.0 A
XL160-07 [CS]	7 V	0.72 A	22.8 A
XL160-08 [CS]	8 V	0.63 A	20.0 A
XL160-12 [CS]	12 V	0.40 A	13.3 A
XL160-15 [CS]	15 V	0.33 A	10.7 A
XL160-19 [CS]	19 V	0.26 A	8.42 A
XL160-24 [CS]	24 V	0.20 A	6.67 A
XL160-28 [CS]	28 V	0.18 A	5.71 A
XL160-30 [CS]	30 V	0.17 A	5.33 A
XL160-33 [CS]	33 V	0.15 A	4.84 A
XL160-48 [CS]	48 V	0.11 A	3.33 A
XL160-51 [CS]	51 V	0.10 A	3.14 A
XL160-54 [CS]	54 V	0.09 A	2.96 A
XL160-56 [CS]	56 V	0.09 A	2.86 A

① Minimum load needed for the Power Good signal to go true (high) and the PS_OK signal to go low

② Assuming no load on V2 output & that cooling requirements are met

Table 3-5 Min/Max Load Currents XL160-05 [CS] thru XL160-56 [CS]

3.4 Cooling

The power supply can be used under certain output loading conditions in natural convection cooling or with forced air-cooling. The XL160 may be mounted in any attitude.

3.4.1 Unrestricted Convection Cooling

The maximum continuous output rating of all DC outputs combined is reduced under natural convection cooling with a maximum ambient temperature of 50°C (see Sections 3.3.1 through 3.3.4). On the XL160-1[ATX], -7[ATX] models, the sum of the V1 and V2 outputs must not exceed 40-watts. On the XL160-8[ATX] models, the V2 output must not exceed 40-watts.

3.4.2 Forced Air Cooling

The maximum continuous rating of all DC outputs combined is 160-watts with a minimum of 10 CFM of forced-air cooling at a maximum of 50°C. On the XL160-1[ATX], -7[ATX] models, the sum of the V1 and V2 outputs must not exceed 100-watts. On the XL160-8[ATX] models, the V2 output must not exceed 100-watts. Airflow must be in the same plane as the circuit board (impinging on any side of the XL160).

3.4.3 High Temperature Derating

The XL160 can be operated at elevated temperatures by derating the total maximum output power (or current) by 2.5%/°C from 50°C to 70°C (see Figure 3-1).

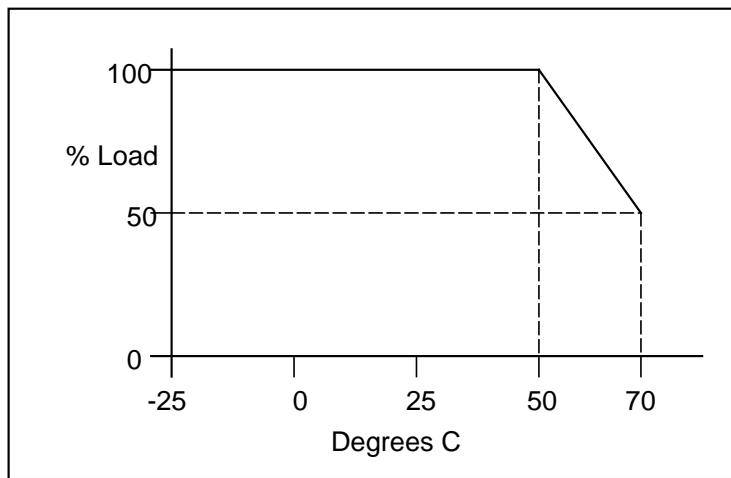

Figure 3-1 XL160 Output Power vs. Ambient Temperature Envelope

3.5 Output Ripple/Noise

Output ripple voltage and noise are defined as periodic or random signals over a frequency band of 10 Hz to 20 MHz. Measurements are to be made with an oscilloscope with at least 20 MHz bandwidth. Outputs should be bypassed at the connector with a 0.1 µF ceramic disk capacitor and a 10 µF tantalum capacitor to simulate system loading (see Figure 3-2). Ripple and noise shall not exceed the limits specified in the following tables.

3.5.1 Ripple/Noise Limits: XL160-1[ATX], -7[ATX], -8[ATX]

The ripple voltage of the outputs is measured at the pins of the mating connector. Ripple and noise shall not exceed the limits specified in Table 3-6 under any condition of line voltage and frequency specified in Section 2.1 and DC loading specified in Section 3.3.1.

Output	Voltage	Maximum Ripple+Noise (peak-to-peak)
V1	+3.3/+2.5/0 V	50 mV
V2	+5 V	50 mV
V3	+12 V	120 mV
V4	-12 V	120 mV
V5	+5 V _{standby}	50 mV

Table 3-6 Ripple Voltage: XL160-1, -7, -8 and ATX versions

3.5.2 Ripple/Noise Limits: XL160-11

The ripple voltage of the outputs is measured at the pins of the mating connector. Ripple and noise shall not exceed the limits specified in Table 3-6 under any condition of line voltage and frequency specified in Section 2.1 and DC loading specified in Section 3.3.1.

Output	Voltage	Maximum Ripple+Noise (peak-to-peak)
V1	+5 V	50 mV
V2	+12 V	120 mV
V3	-12 V	120 mV

Table 3-7 Ripple Voltage: XL160-11

3.5.3 Ripple/Noise Limits: XL160-10

The ripple voltage of the outputs is measured at the pins of the mating connector. Ripple and noise shall not exceed the limits specified in Table 3-6 under any condition of line voltage and frequency specified in Section 2.1 and DC loading specified in Section 3.3.1.

Output	Voltage	Maximum Ripple+Noise (peak-to-peak)
V1	+5.6 V	56 mV
V2	-5.8 V	58 mV

Table 3-8 Ripple Voltage: XL160-10

3.5.4 Ripple/Noise Limits: XL160-05 [CS] through XL160-56 [CS]

The ripple voltage of the outputs is measured at the pins of the mating connector. Ripple and noise shall not exceed the limits specified in Table 3-9 under any condition

of line voltage and frequency specified in Section 2.1 and DC loading specified in Section 3.3.2.

Model	Rated V1 Output	Maximum Ripple+ Noise (peak-to-peak)
XL160-05 [CS]	5 V	50 mV
XL160-07 [CS]	7 V	70 mV
XL160-08 [CS]	8 V	80 mV
XL160-12 [CS]	12 V	120 mV
XL160-15 [CS]	15 V	150 mV
XL160-19 [CS]	19 V	190 mV
XL160-24 [CS]	24 V	240 mV
XL160-28 [CS]	28 V	280 mV
XL160-30 [CS]	30 V	300 mV
XL160-33 [CS]	33 V	330 mV
XL160-48 [CS]	48 V	480 mV
XL160-51 [CS]	51 V	510 mV
XL160-54 [CS]	54 V	540 mV
XL160-56 [CS]	56 V	560 mV
All of the above	V2 (12V)	120 mV

Table 3-9 Ripple Voltage: XL160-05 [CS] thru XL160-56 [CS]

3.5.5 Ripple/Noise Test Setup

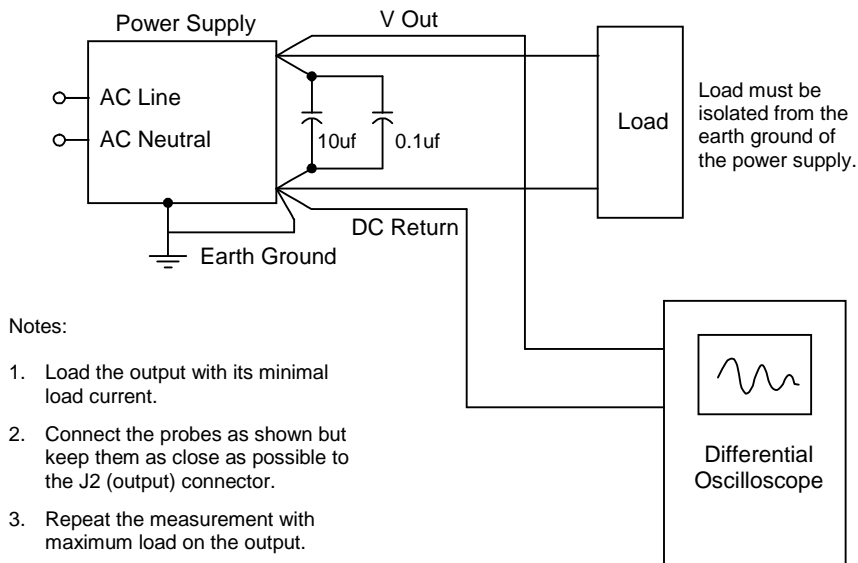

Figure 3-2 Ripple Noise Measurement Setup

3.6 Local and Remote Sensing

Remote sensing is provided to compensate for voltage drops in the V1 (+ Output) and DC RETURN connections to the load. XL160-1, -7 and -8 models (non-ATX) have an additional sense input of the V2 (+ Output). For every model, the 0V Sense input must always be connected to either one of the DC Return pins of the XL160 or the DC Return terminal at the load. Connecting it to the return side of the load will reduce the voltage drop in the external return wiring.

If the V1 Sense input is left open, the V1 output may not meet its load regulation specification. The V1 output will meet its load regulation specification when the V1 Sense pin is connected to one of the V1 output pins. Connecting the V1 Sense pin to the V1 output at the load will reduce the voltage drop in the external V1 wiring.

3.6.1 Local and Remote Sensing: XL160-1[ATX], -7[ATX], -8[ATX]

The V1 +Sense input need not be connected for the XL160-8 or XL160-8ATX, as they have no V1 output. The XL160-1[ATX] and XL160-7[ATX] can compensate for up to 0.2V drop in each side (+ Output and DC RETURN) of the V1 output. The +Sense on J3-1 affects only the V1 output while the –Sense on J3-2 affects V1, V2 and V3. Figure 3-3 shows the required and optional remote sensing connections. Note that on the ATX versions J3 has 5-pins instead of the 3-pins shown below, but pins 1 and 2 are still used for remote sense as shown in Figure 3-3. Refer to Table 4-7 for the pin definition of the XL160 connectors.

XL160-1, -7 and -8 models (non-ATX versions) have an additional +V2 sense pin at J4 (see Figure 4-3). This pin may be connected to +5V load to reduce the voltage drop in the V2 load wiring. The +V2 sense input does not affect the V1, V4 or V5 voltages.

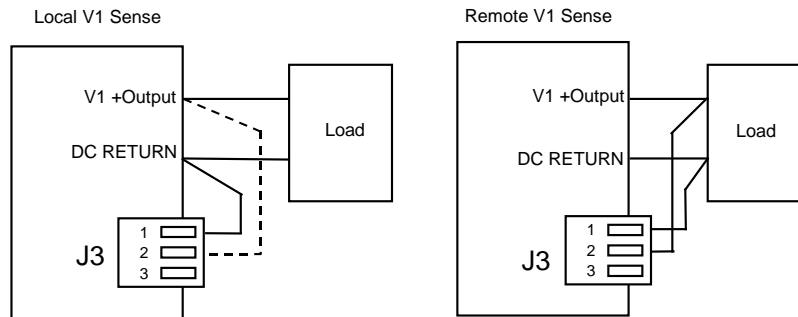

Figure 3-3 Remote V1 Sensing: XL160-1[ATX], -7[ATX], -8[ATX]

3.6.2 Local and Remote Sensing: XL160-05 [CS], XL160-07 CS, XL160-08 CS

Up to 0.2V in the return and 0.2V in the V1 connection may be compensated. Figure 3-4 shows the required and optional remote sensing connections. J3 actually has five pins but only the first three are shown below. Refer to Table 4-8 for the pin definition of the XL160 connectors.

This model contains an internal OR-ing diode so that V1 output of multiple power supplies may be connected in parallel. Follow the same sense wiring for each paralleled supply as if it were a single supply.

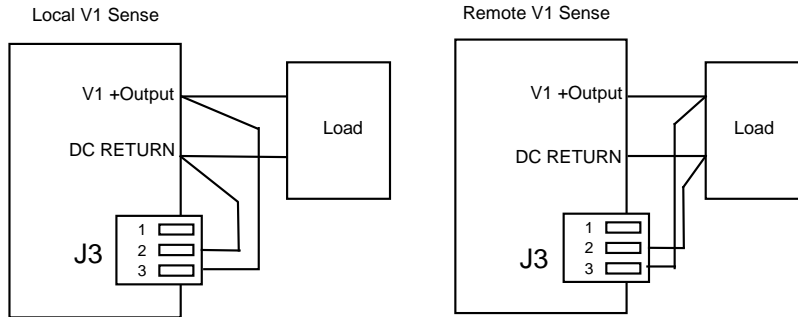

Figure 3-4 Remote Sensing Wiring: XL160-05 [CS], -07 CS and -08 CS

3.6.3 Local and Remote Sensing: XL160-10

Up to 0.2V in the return and 0.2V in the V1 connection may be compensated. The + and – sense inputs are found on J3 and affect only the V1 output.

3.6.4 Local and Remote Sensing: XL160-11 CS

Up to 0.2V in the return and 0.2V in the V1 connection may be compensated. The +Sense input is found on the single-pin header J4 (see Figure 4-3). The –Sense input is found on J3-1. Both sense inputs affect the V1 and V2 outputs but not V3.

3.6.5 Local and Remote Sensing: XL160-12 [CS] through XL160-56 [CS]

Up to 0.5V in the return and 0.5V in the V1 connection may be compensated. Figure 3-5 shows the required and optional remote sensing connections. J3 actually has five pins but only the first three are shown below. Refer to Figure 4-3 for the pin definition of the XL160 connectors. These models contain internal OR-ing diodes so that V1 output of multiple power supplies may be connected in parallel. Follow the same sense wiring for each paralleled supply as if it were a single supply.

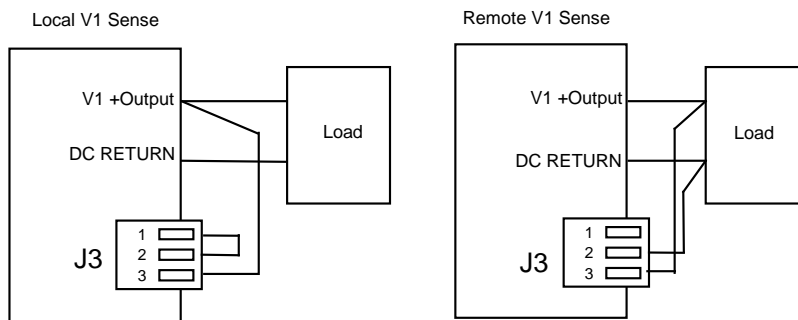

Figure 3-5 Remote Sensing Wiring: XL160-12 [CS] through XL160-56 [CS]

3.7 Parallel Operation

3.7.1 XL160-05 CS, -07 CS, -08 CS and XL160-12 CS through -56 CS

The V1 output of two, three or four XL160-xx CS power supplies may be connected directly in parallel to provide higher output power. They can also be used in an N+1 configuration to provide higher output power and greater reliability. Each of these models has a built-in V1 output OR-ing diode (or MOSFET) and a Current Share signal for active load-leveling parallel operation.

The V2 outputs must not be connected together and they are unaffected by the active current sharing of the V1 outputs.

3.7.2 Current Sharing Connections

The Current Share signal (see Table 4-7) of each supply operating in parallel must be connected together. Power sharing does not require the 0V Sense signals be connected together, but the sharing accuracy may not meet published specification unless they are also connected together.

Power Good signals may be wire OR-ed together, but this is not recommended, as a failing power supply will pull the signal low. They should be monitored individually by the user's system.

3.7.3 Current Share Accuracy

When all the current share signals are connected together and all the 0V Sense signals are connected together, the load delivered by any two supplies of the sharing supplies will not vary by more than 10% at full load.

3.7.4 Transients

The output rise time and monotonic requirements of Section 6.1 may not be met where the load exceeds 160 watts, because of the difference in start-up times of the paralleled power supplies.

When the AC line to one of the parallel power supplies is disconnected or reconnected, or a power supply fails, the transient on the V1 output is within five (5) percent of nominal output voltage, although the output voltage may ramp to a new nominal voltage within the regulation band.

3.7.5 XL160-11

The XL160-11 has output OR-ing diodes on both the V1 and V2 outputs. For redundancy purposes, these outputs may be connected in parallel with those of identical supplies. However, the total output power available is still the same as a single supply. Multiple V3 outputs may not be connected together.

3.8 Output Protection

There are three different output protection schemes designed to protect the load and the XL160 from component failures and extraordinary circumstances.

3.8.1 Over Temperature Protection

If the XL160 is operated without adequate cooling, it will sense an over-temperature condition and shut itself down. It will not restart until it has cooled down to below its maximum operating temperature and the AC power is turned off and back on.

3.8.2 V2 or V3 Outputs Over-Load Protection

The V2 outputs of the XL160-05, 07, -08, and -12 through -56 are current limited at approximately 1.5A through a thermally protected linear regulator. The same is true for the V3 output on the XL160-11. The V2 output (-5.8V) of the XL160-10 is current limited at approximately 2A through a thermally protected linear regulator.

An overload on the V2 output (V3 on the XL160-11) should not affect the operation of the other outputs unless the V2 output power adds to already excessive output power, thereby causing over-power protection. The V2 output will resume normal operation when the over-load condition is removed.

3.8.3 Over-Power Protection

Total output power in excess of approximately 190-watts will cause the XL160 to shut down all outputs except for the V5 (+5Vstandby) output on ATX models. The power supply will periodically attempt to restart until the over-load condition is removed.

Pulsating loads of 150% of the rated output can be sustained for 10-milliseconds provided the duty cycle does not exceed 10%. The total RMS power must still be limited to 160-watts.

3.8.4 Over Voltage Protection

No single fault is able to cause a sustained over voltage condition on any output. The following outputs have OVP sensing and will shut the supply down if the output reaches the OVP threshold. Following an OVP event, the XL160 will not restart until AC power is turned off and back on.

Model	OVP Sensing on Outputs:
XL160-1,-7[ATX]	V1, V2, V3
XL160-8[ATX]	V2, V3
XL160-11	V1, V2
XL160-10	V1
XL160-XX [CS]	V1

Table 3-10 OVP Protected Outputs by Model

The XL160 will shut down under the following over voltage conditions:

Rated Output Voltage	Minimum OVP Threshold	Nominal OVP Threshold	Maximum OVP Threshold
2.5 V	2.87 V	3.15 V	3.44 V
3.3 V	3.76 V	4.2 V	4.9 V
5.0 V	5.74 V	6.3 V	6.88 V
5.6 V	6.30 V	7.0 V	7.70 V
7 V	7.88 V	8.7 V	9.63 V
8 V	9.00 V	10.0 V	11.0 V
12 V	13.5 V	15.0 V	16.5 V
15 V	16.9 V	18.8 V	20.6 V
19 V	21.4 V	23.8 V	26.1 V
24 V	27.0 V	30.0 V	33.0 V
28 V	31.5 V	35.0 V	33.5 V
30 V	33.8 V	37.5 V	41.3 V
33 V	37.1 V	41.3 V	45.4 V
48 V	54.0 V	58.0 V	66.0 V
51 V	57.4 V	63.8 V	70.1 V
54 V	60.8 V	64.8 V	74.3 V
56 V	63.0 V	70.0 V	77.0 V

Table 3-11 Over Voltage Protection Limits by Rated Output Voltage

3.9 Output Rise Time

All output voltages shall rise from 10% to 90% of nominal output voltage (as specified in Table 3-1) within 0.2ms to 20ms. The output voltages waveform must be a monotonic ramp from 10% to 90% of final setpoint within the regulation band under any loading conditions specified in the respective load current tables in Section 6.

For the purposes of this specification, a monotonic ramp is defined as always having a positive slope of from zero to $10 \times V_{out}$ volts/millisecond. During any 5-millisecond portion of the ramp, its slope must greater than 5% of its rated voltage per millisecond.

3.10 Overshoot At Turn On/Turn Off

The output voltage overshoot upon the application or removal of the input mains voltage is less than 10% above the nominal voltage. No opposite polarity voltage is present on any output during turn on or turn off.

3.11 Output Transients

The maximum output voltage transient caused by step load changes will not exceed the output voltage regulation limits by more than 5%. With an AC input as specified in Section 2.1, the power supply will remain stable when subjected to the load transients described below:

- Load changes between 75% and 100% on any output
- Load changing repetition of 50 to 333 cycles per second
- Transient load slew rate = 1.0 A/microsecond
- Capacitive loading per Table 3-12

3.12 Closed Loop Stability

The power supply is unconditionally stable under all line/load/transient load conditions including the capacitive loads specified in Table 3-12. The power supply shall exhibit a minimum of 45-degrees phase margin and 6 dB gain margin.

3.13 Capacitive Loading

The power supply will power up and operate normally with the capacitances listed in Table 3-12 simultaneously present on the outputs.

XL160-:	-1[ATX], -7[ATX], -8[ATX]	-05 thru -11	-12	-15 thru -19	-24 thru -33	-48 thru -56
Output:	have demonstrated starting and stability with the following capacitive loads					
+3.3 V / +2.5 V	6,000 μ F					
+5 V	10,000 μ F					
+5 V _{standby} (ATX)	100 μ F					
+12 V	1,000 μ F					
V1 (Main Output)		10,000 μ F	4,000 μ F	3,000 μ F	2,000 μ F	500 μ F
12 V _{aux}	350 μ F	350 μ F	350 μ F	350 μ F	350 μ F	350 μ F

Table 3-12 XL160 Demonstrated Capacitive Loading

4.

General Specifications

4.1 Environmental

The XL160 meets or exceeds the following environmental specifications:

Parameter	Conditions	Specification	Remarks
Temperature	Operating	-25°C to 50°C	See cooling requirements
	Non-Operating	-40°C to 85°C	
Relative Humidity	Operating	95% Maximum	Non-Condensing
	Non-Operating	95% Maximum	Non-Condensing
Altitude	Operating	6,561 feet MSL Max.	2,000 meters
	Non-Operating	50,000 feet MSL Max.	15,240 meters
Vibration	No damage	2.4G RMS Maximum	5-500Hz, 10-min. each axis per MIL-PRF-28800F: 3.8.4.1 (Class 3,4)
		6.0G RMS Maximum	100-1,000Hz random, 10-min. vertical axis only
Mechanical Shock	No damage	30G half-sine, 11mS	Six shocks each axis per MIL-PRF-28800F: 4.5.5.4.1

Table 4-1 Environmental Specifications

4.2 Mean Time Between Failures

The calculated MTBF of XL160-1, 7 and 8 models is equal to or greater than 525,000 hours of continuous operation at maximum output loading and worst case input line voltage with forced-air cooling at 25°C. The ATX versions of XL160-1, 7 and 8 are rated at 430,000 hours. The XL160-12 thru 56 CS models are rated at 675,000 hours. N2Power does not warrant the MTBF to be representative of any particular unit. The MTBF of the power supply is calculated with an 80% confidence level in accordance with Bellcore, SR-332, Issue 2. Actual failure rates vary from unit to unit.

4.3 Component Stress

The XL160 design followed these component-derating guidelines: semiconductor junction temperatures shall not exceed ninety (90) percent of manufacturer's rating with an ambient of 50°C. Inductor winding temperatures shall not exceed safety agency requirements. Capacitor case temperatures shall not exceed 95% of rated temperature. Resistor power dissipation derating is greater than 30%. Component voltage and current derating is greater than 10% at 50°C.

4.4 Labeling/Marking

The power supply is marked and labeled with the N2Power logo and part number, model number, input and output specifications, production code, appropriate safety agency logos, CE mark, patent number, and country of origin. A typical label is pictured below.

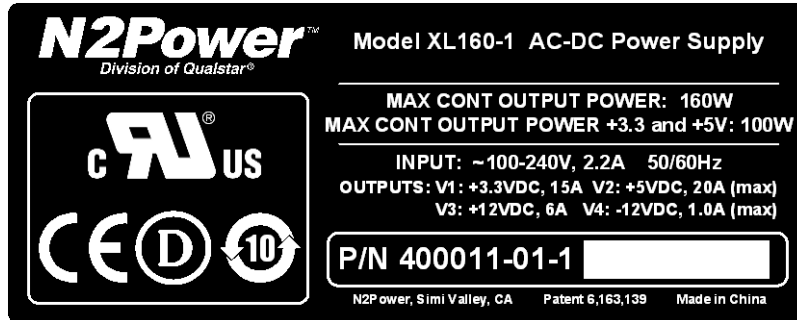

Figure 4-1 Sample XL160 Label

4.5 Weight

Model	Pounds	Ounces	Kilograms
XL160-1ATX, -7ATX	0.70	11.2	0.32
XL160-8ATX	0.66	10.6	0.30
XL160-1, -7	0.68	10.9	0.31
XL160-8	0.64	10.3	0.29
XL160-10	0.66	10.6	0.30
XL160-11	0.65	10.4	0.30
XL160-05 [CS], -07 CS, -08 CS	0.63	10.1	0.29
XL160-12 [CS] thru -56 [CS]	0.59	9.5	0.27

Table 4-2 XL160 Weights

4.6 Mounting

The XL160 may be mounted in any attitude but must be mounted on all four corners. No. 6 or M3 mounting hardware should not exceed .282-inches (7.16-mm) in diameter for any lockwasher, flat washer, standoff, screw head or other mounting hardware to avoid contact and maintain adequate safety agency spacing requirements with components or printed circuit board traces.

4.7 Physical Dimensions

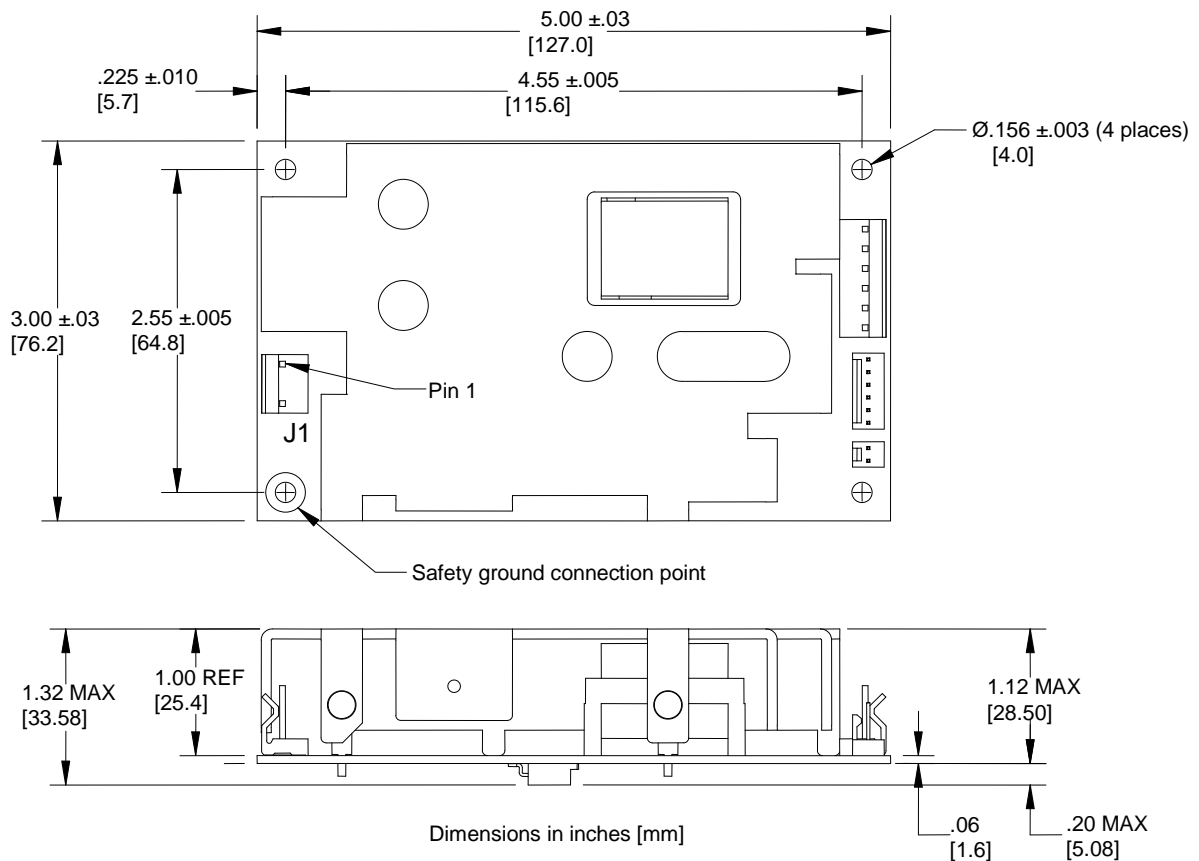

Note: Recommended standoff size is .375" high minimum and all mounting hardware should be less than .28 inches in diameter. A .25" high standoff is acceptable when a thin insulator, 0.4mm thick (polyester, fish paper or equivalent UL rated 94V-2 minimum) is placed between the XL160 and the mounting chassis (refer to applicable UL standard for clearance requirements).

Figure 4-2 XL160 Dimensions

4.8 Mating Connectors

The user must furnish all mating connectors. The mating connectors must meet the requirements of all applicable safety agencies (notably UL). Molex™ (Molex is a trademark of the Molex Corporation) did not change their part numbers when they took the lead out of their contacts. The Molex part numbers in this section should yield RoHS compliant contacts. The largest wire size accepted by each contact should be used for all power connections to help dissipate the heat generated by the resistive connections.

Note that the female contacts that mate to the power supply are only rated for 25-30 mating cycles. Excessive mating cycles causes dramatically increased terminal resistance and heating resulting in the eventual failure of the mating terminal and possibly the header on the power supply.

CAUTION

The pin-1 location differs amongst connector manufacturers. Sometimes pin-1 differs between the header (on the power supply) and the mating housing from the same manufacturer. Disregard the manufacturer's pin-1 location and follow only the pin-1 locations in Figure 4-3.

4.8.1 AC Input Mating Connector (J1)

The AC input connector to the XL160 is a 3-pin Molex™ (Molex is a trademark of the Molex Corporation) KK style header with 0.156" centers. The center pin is omitted to provide adequate insulation spacing. The Molex part numbers for the mating housing and crimp-style snap-in terminals are listed below. There may be equivalent connectors available from other manufacturers. The line side of the input should be connected to the pin closest to the mounting hole (see Figure 4-2).

J1	Molex P/N
Connector Circuits (pins)	2 of 3
Mating Housing	09-50-8031
Rated Contact Current	7.0 A
Crimp Terminal (tin)	08-50-0106
Rated Wire Size	AWG 18 or 20

Table 4-3 J1 Mating Connector

4.8.2 DC Output Connector (J2)

Except for the XL160-2, the DC output connector is a Molex KK style header with 0.156" centers. The Molex part numbers for the mating housing and crimp-style snap-in terminals are listed below. There may be equivalent connectors available from other manufacturers.

J2	XL160-1[ATX], -7[ATX], -8[ATX], XL160-11 CS	XL160-05 [CS], -07 CS, -08 CS, -10	XL160-xx [CS]
Connector Circuits (pins)	14	6	6
Mating Housing	09-50-8141	Stripped and tinned wire	09-50-8061
Crimp Terminal (tin)	08-52-0071	N/A	08-50-0106
Rated Wire Size	AWG 18 or 20	AWG 12 max.	AWG 18 or 20

Table 4-4 J2 Mating Connectors

4.8.3 Remote Sense / PG Connector (J3)

The Remote Sense/PG connector on the XL160 is a Molex KK style header with 0.100" centers. The Molex part numbers for the mating housing and crimp-style snap-in terminals are listed below. There may be equivalent connectors available from other manufacturers.

J3	XL160-1, -7, -8 XL160-11*	XL160-1ATX, -7ATX, -8ATX, XL160-05 [CS], -07 CS, -08 CS XL160-10	XL160-xx [CS]
Connector Circuits (pins)	3	5	6
Mating Housing	22-01-3037	22-01-3057	22-01-3067
Crimp Terminal (tin, 2.5A)	08-52-0123	08-52-0123	08-52-0123
Rated Wire Size	AWG 22 to 30	AWG 22 to 30	AWG 22 to 30

* For XL160-1, 7, 8 and 11 models only, it is recommended to use the Molex 22-01-3037 housing and not an equivalent from another manufacturer.

Table 4-5 J3 Mating Connectors

4.8.4 J4 Connector: 12V Aux or V2 Sense (see Table 4-7 & Table 4-8)

The 12V AUX or V2 Sense connector (see Table 4-6) is a 2-pin header with 0.100" centers. The part numbers for the mating housing and crimp-style snap-in terminals are listed below. There may be equivalent connectors available from other manufacturers.

J4 on the XL160-1,7,8 models is a single pin header for remote sensing the V2 (+5V) output. Remote sensing will help eliminate the voltage drop in the wires from the XL160-1,7,8 to the load. This pin should be connected to the +5V output at the load, not J2.

J4	XL160-05 [CS], -07 CS, -08 CS XL160-xx [CS] XL160-10	XL160-11 XL160-1, -7, -8 (not ATX)
Connector Circuits (pins)	2	1
Mating Housing	Molex P/N 22-01-3027	Molex P/N 22-01-2011 or TE Connectivity Ltd P/N 7-87499-2
Crimp Terminal (tin, 2.5A)	Molex 08-52-0123	Molex 08-52-0123 or TE Connectivity Ltd P/N 6-87756-6
Rated Wire Size	AWG 22 to 30	AWG 22 to 30

Table 4-6 J4 Mating Connectors

4.9 Output Grounding

The DC RETURN signal may be connected to the power supply chassis ground (safety ground) at the plated through mounting hole near the input connector.

4.10 Signal Pin Definitions

- There are three general output connector configurations for the XL160 Series
- Identical signal names are connected together on all connectors
- The V2 output (12V aux) is floating only on models XL160-05, -07, -08, -12 through -56
- The safety ground connection is provided by the mounting screw near J1
- Refer to Figure 4-3 for connector and pin-1 locations
- Refer to Table 6-1 for signal level definitions

Pin	XL160-1[ATX], -7[ATX]	XL160-8[ATX]	XL160-11 CS
J1-1	AC Neutral	AC Neutral	AC Neutral
J1-2	No Pin	No Pin	No Pin
J1-3	AC Line	AC Line	AC Line
J2-1	V4 (-12V Output)	V4 (-12V Output)	V3 (-12V Output)
J2-2	V3 (+12V Output)	V3 (+12V Output)	V2 (+12V Output)
J2-3	V1 (+2.5/+3.3V Output)	V3 (+12V Output)	V2 (+12V Output)
J2-4	V1 (+2.5/+3.3V Output)	V3 (+12V Output)	V2 (+12V Output)
J2-5	V1 (+2.5/+3.3V Output)	V3 (+12V Output)	V2 (+12V Output)
J2-6	DC RETURN (0V)	DC RETURN (0V)	DC RETURN (0V)
J2-7	DC RETURN (0V)	DC RETURN (0V)	DC RETURN (0V)
J2-8	DC RETURN (0V)	DC RETURN (0V)	DC RETURN (0V)
J2-9	DC RETURN (0V)	DC RETURN (0V)	DC RETURN (0V)
J2-10	DC RETURN (0V)	DC RETURN (0V)	DC RETURN (0V)
J2-11	V2 (+5V Output)	V2 (+5V Output)	V1 (+5.3V Output)
J2-12	V2 (+5V Output)	V2 (+5V Output)	V1 (+5.3V Output)
J2-13	V2 (+5V Output)	V2 (+5V Output)	V1 (+5.3V Output)
J2-14	V2 (+5V Output)	V2 (+5V Output)	V1 (+5.3V Output)
J3-1	0V Sense (-)	0V Sense (-)	0V Sense (-)
J3-2	V1 Sense (+)	Not Used	Not Used
J3-3	Power Good	Power Good	Power Good
J3-4	ATX only: PS_ON/	ATX only: PS_ON/	
J3-5	ATX only: +5 V _{standby}	ATX only: +5 V _{standby}	
J4-1	+V2 Sense (Note 1)	+V2 Sense (Note 1)	+V1 Sense

Note 1: ATX Versions have no J4

Table 4-7 XL160 Signal Pin Definitions (Part A)

Pin	XL160-10	XL160-05 [CS], -07 CS, -08 CS	XL160-xx [CS]
J1-1	AC Neutral	AC Neutral	AC Neutral
J1-2	No Pin	No Pin	No Pin
J1-3	AC Line	AC Line	AC Line
J2-1	V1 (+5.6V Output)	V1 (+5V Output)	V1 (+ Output)
J2-2	V1 (+5.6V Output)	V1 (+5V Output)	V1 (+ Output)
J2-3	V1 (+5.6V Output)	V1 (+5V Output)	V1 (+ Output)
J2-4	DC RETURN (0V)	DC RETURN (0V)	DC RETURN (0V)
J2-5	DC RETURN (0V)	DC RETURN (0V)	DC RETURN (0V)
J2-6	DC RETURN (0V)	DC RETURN (0V)	DC RETURN (0V)
J3-1	Current Share	Current Share	DC RETURN (0V)
J3-2	0V Sense (-)	0V Sense (-)	0V Sense (-)
J3-3	V1 Sense (+)	V1 Sense (+)	V1 Sense (+)
J3-4	PS_OK	PS_OK	Current Share
J3-5	Power Good	Power Good	Power Good
J3-6	No Pin	No Pin	PS_OK
J4-1	DC RETURN (0V)	+12V AUX (Fan)	V2 (+12V AUX)
J4-2	V2 (-5.8V Output)	DC RETURN (0V)	V2 (-12V AUX)

Table 4-8 XL160 Signal Pin Definitions (Part B)

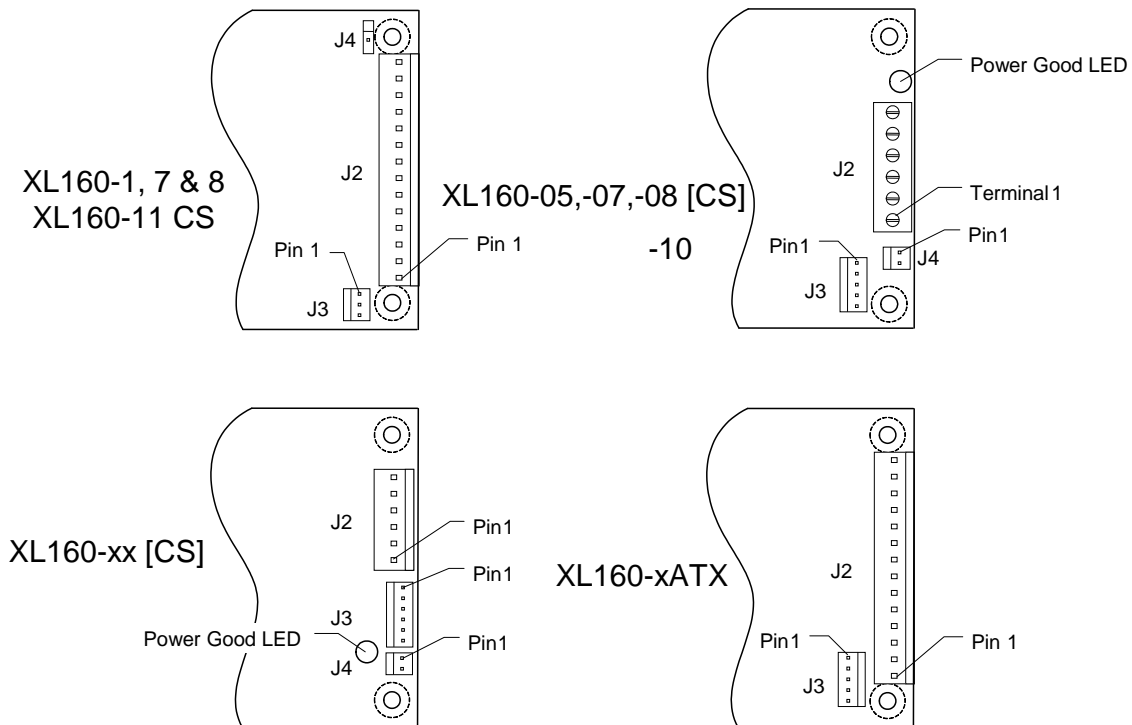

Figure 4-3 XL160 Output Connectors Layouts

5.

Efficiency

The power supply will meet high efficiencies under defined loading conditions specified in Table 5-1 with a line voltage of 230VAC and 10 CFM of cooling air at 25°C. Efficiency curves are shown in the following diagrams. These charts are for Current Sharing (CS) models, removing the Or-ing diodes will increase the efficiency by approximately 2%. This is available as an option.

XL160:	-1[ATX]	-05 [CS]	-12 [CS]	-15 [CS]	-24 [CS]	-48 [CS]	-7	-8
Efficiency	84%	83%	84%	85%	87%	88%	84%	84%
V1	3.8 A	25.6 A	10.6 A	8.5 A	5.3 A	2.7 A	5.0 A	-
V2	8.0 A	0.0 A	0.0 A	0.0 A	0.0 A	0.0 A	8.0 A	10.5 A
V3	6.0 A	-	-	-	-	-	6.0 A	6.0 A
V4	0.3 A	-	-	-	-	-	0.3 A	0.3 A
V5	0.3 A (-1ATX)							

Table 5-1 XL160 Output Currents at Rated Efficiency

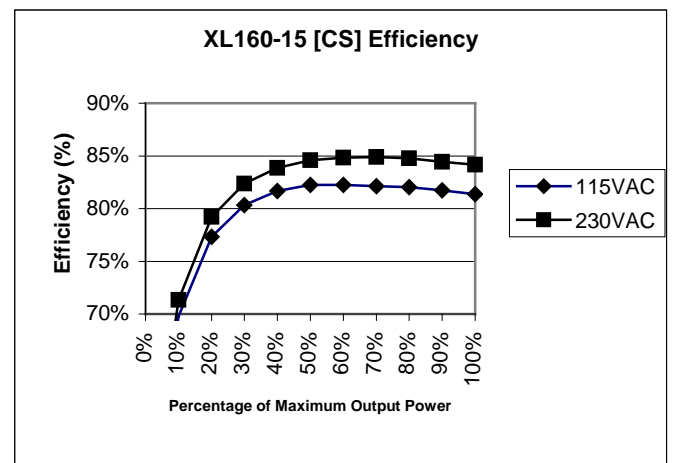
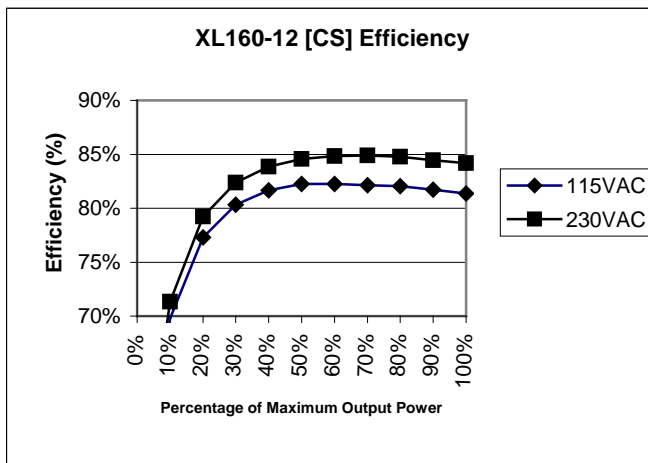
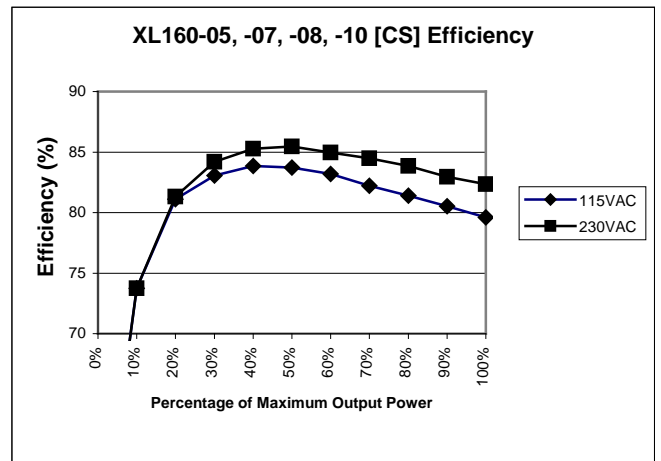
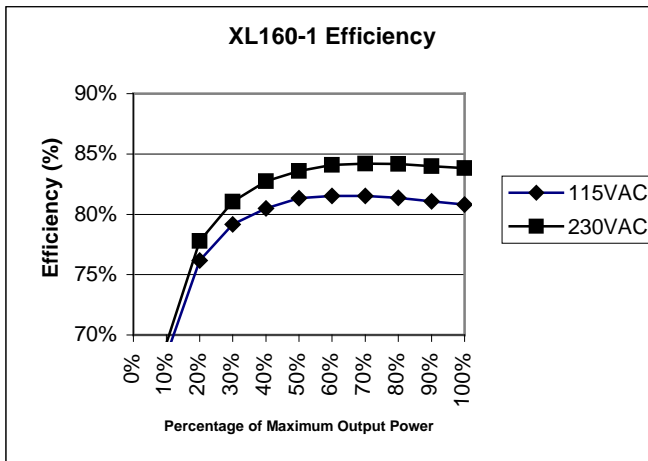

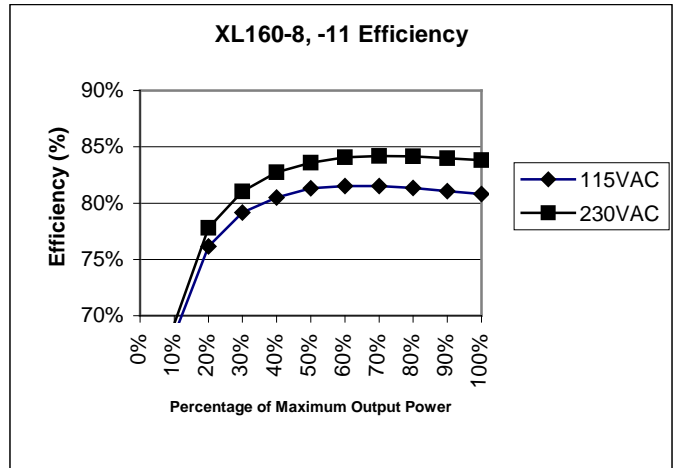
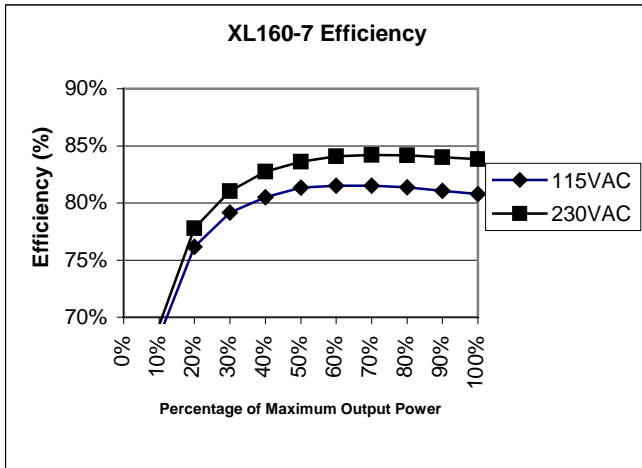
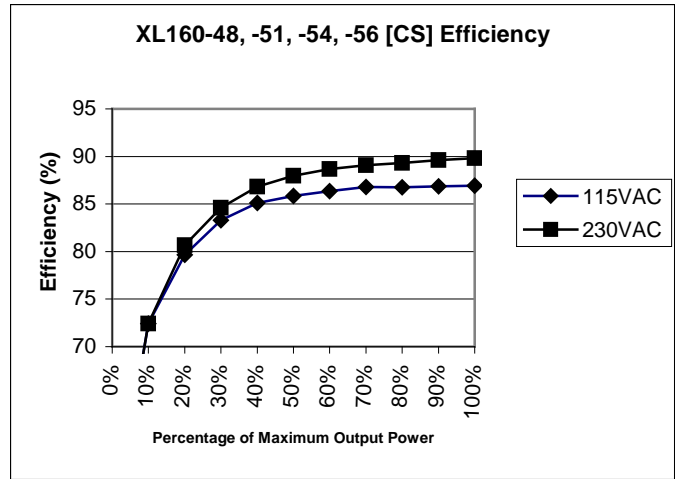
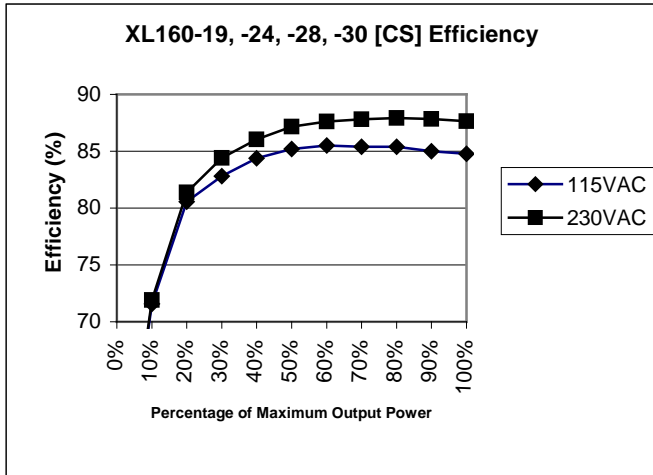

6.

Timing and Control

6.1 Power Supply Timing

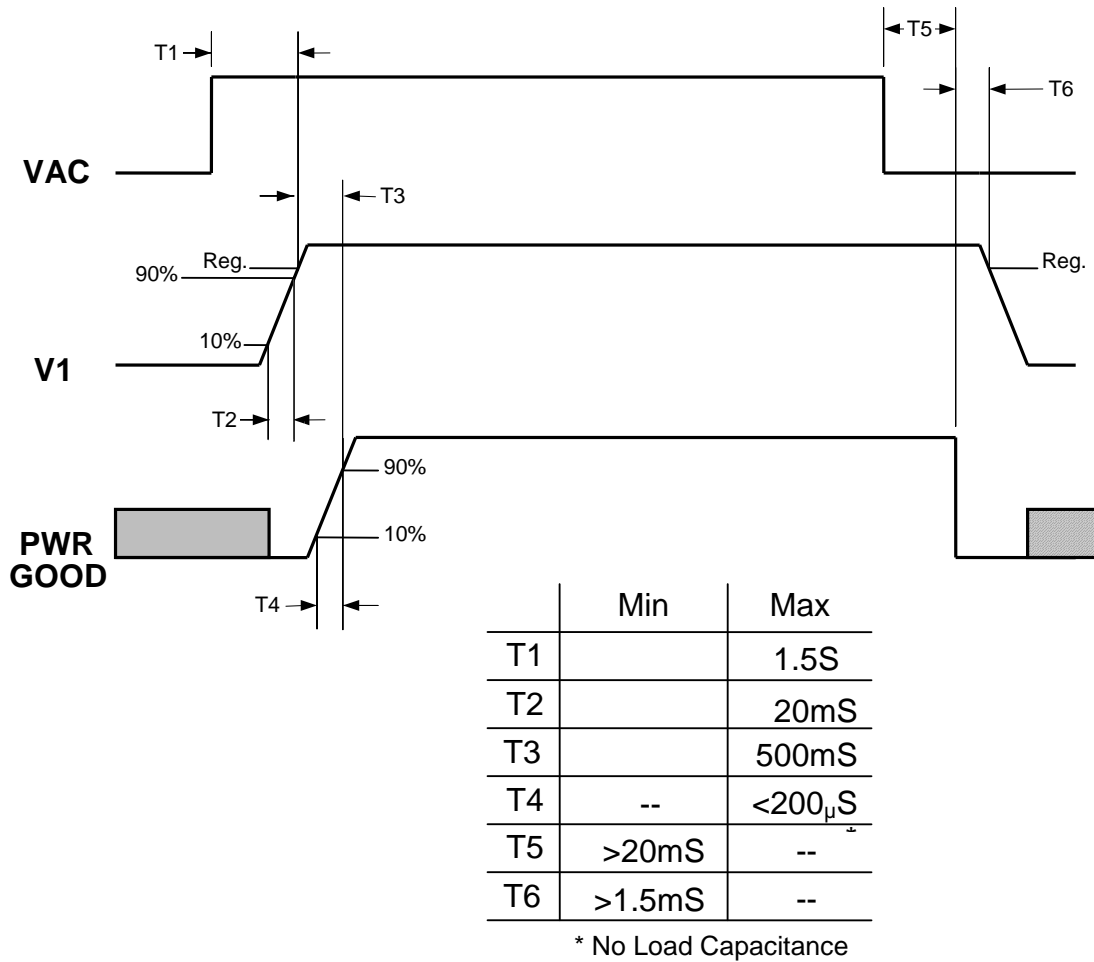

Figure 6-1 XL160 Timing Diagram

6.2 Power Good Signal/PS_OK Signal/Remote ON Input

The Power Good Signal provides a high logic level to indicate that sufficient time has expired for the DC outputs to be within their regulation limits and that sufficient mains energy is stored by the power supply to ensure continuous power operation within specification for the duration of the hold-up time. When the AC mains power is removed for a period longer than 20ms, the Power Good Signal transitions to a low logic level. The PS_OK signal is the logical complement of the Power Good signal and both signals are driven by open-collector NPN transistors. XL160-1, -7 and -8 models

add a TTL compatible pull-up resistor on just the Power Good output. The electrical specifications for the Power Good and PS_OK outputs are described in Table 6-1.

On the ATX versions, the V1 through V4 outputs are enabled whenever the PS_ON/ input (J3 pin-4) is grounded to DC RETURN (or J3 pin-1). Opening the PS_ON/ input will disable the four outputs and cause the Power Good output to go false. The PS_ON/ input has an internal 1K-ohm pull-up resistor connected to +5 V_{standby}

Signal Type	+5VDC, TTL Compatible
Low Logic Levels	<0.4V when sinking 4mA
High Logic Levels	Open Collector Output (see next above)
Power Good output	High true (open) when conditions described above are met
Power Good Pullup Resistor	TTL compatible only on XL160-1, -7 and -8 models
Power On Delay	Less than 500mS after V1 outputs reaches regulation
Power Down Warning	>2 mS before V1 reaches minimum regulated output
Rise Time	<200 μS from 10% to 90% point.
PS_OK Output	Logical complement of Power Good signal. Open collector output without a pull-up resistor
PS_ON/ (input)	Operate < 0.8V, Standby > 2.0V, Load: 1.0 K pull-up to +5 V

Table 6-1 XL160 Status Signal Specifications

6.3 Power Good LED

A green LED on XL160-05 [CS], -07 CS, -08 CS, and XL160-xx [CS] models illuminates whenever the Power Good signal is true (high). See Figure 4-3 for the LED location near the output connector.

6.4 Power Sequencing: XL160-1[ATX] and XL160-7[ATX]

The +12V and +5V output voltages are equal to or greater than the V1 (+2.5V or +3.3V) output voltage at all times during power up and normal operation. The time between the +5V output reaching minimum in-regulation voltage and the V1 output reaching minimum in-regulation voltage shall be less than 20 milliseconds.

6.5 Voltage Hold-Up Time

The power supply will maintain output regulation per Table 3-1 despite a loss of input power at 100VAC/50Hz and 230VAC/47Hz at maximum continuous output load for a minimum of 22 milliseconds. The Power Good and PS_OK signals provide a minimum 2mS warning of impending loss of output power.

7.

Ordering Information

The following table provides the N2Power part numbers that should appear on your purchase order and will appear on any N2Power correspondence:

XL160 Models without active current sharing			
New Model Number	V1	P/N	Legacy Model Number
XL160-1ATX	3.3	400011-04-5	XL160-1ATX
XL160-7ATX	2.5	400017-02-6	XL160-7ATX
XL160-8ATX	N/A	400018-07-3	XL160-8ATX
XL160-1	3.3	400011-01-1	XL160-1
XL160-7	2.5	400017-01-8	XL160-7
XL160-8	N/A	400018-01-6	XL160-8
XL160-11	5.3	400060-01-8	XL160-8 S21
XL160-05	5.0	400012-06-8	XL160-2 or XL160-2 S46
XL160-12	12	400013-12-4	
XL160-15	15	400014-03-1	
XL160-24	24	400015-07-9	
XL160-28	28	400015-13-7	
XL160-48	48	400016-07-7	
XL160-51	51	400016-08-5	XL160-6 S10
XL160-54	54	400033-02-3	
XL160-56	56	400034-02-1	
XL160-10	5.6	400028-01-5	
XL160 Models with active current sharing			
New Model Number	V1	P/N	Legacy Model Number
XL160-05 CS	5.0	400012-01-9	XL160-2
XL160-07 CS	7.0	400012-05-0	XL160-2 S16
XL160-08 CS	8.0	400012-10-0	
XL160-12 CS	12	400013-01-7	XL160-3
XL160-15 CS	15	400014-01-5	XL160-4
XL160-19 CS	19	400015-04-6	XL160-5 S38
XL160-24 CS	24	400015-01-2	XL160-5
XL160-28 CS	28	400015-12-9	
XL160-30 CS	30	400015-08-7	XL160-5 S44
XL160-33 CS	33	400015-10-3	
XL160-48 CS	48	400016-01-0	XL160-6
XL160-51 CS	51	400016-03-6	XL160-6 S10
XL160-54 CS	54	400033-01-5	
XL160-56 CS	56	400034-01-3	

Table 7-1 XL160 Model and Part Numbers

For warranty information refer to www.n2power.com

All XL160 power supplies are RoHS compliant.

Direct all questions, orders or requests for quotation as follows:

SMX POWER 3005 Avenida Simi, Simi Valley, CA 93063
TEL: (805) 582-2804 FAX: (805) 582-2308 <http://www.smxpower.com>