

ACC-GPS65-2

Accessory Kit - 'L' Bracket.

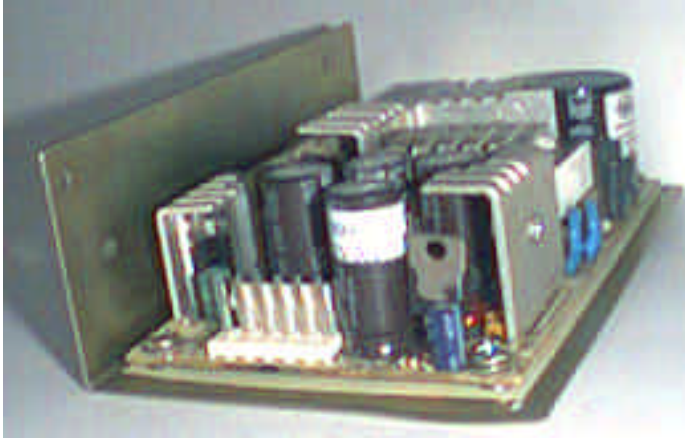

- 'L' Bracket.
- Insulator.
- Mounting Screws and Washers.
- Assembly Instructions.

ASSEMBLY INSTRUCTIONS

1. Before assembly ensure unit has been turned OFF for at least 10 minutes.
2. "A" denotes customer mounting holes threaded 6-32 (4 nos.).
Maximum penetration into customer mounting hole is 0.10 inch.
3. "B" denotes PSU fixing stand-offs. Use screws 6-32 x 0.25" (4 nos.)

Note : When 'L Bracket' is fitted other than by the manufacturer, it is the user's responsibility to ensure that the requirement of the relevant safety agency or agencies are complied with.

ORDERING INFORMATION

Model : ACC-GPS65-2

MECHANICAL DETAILS

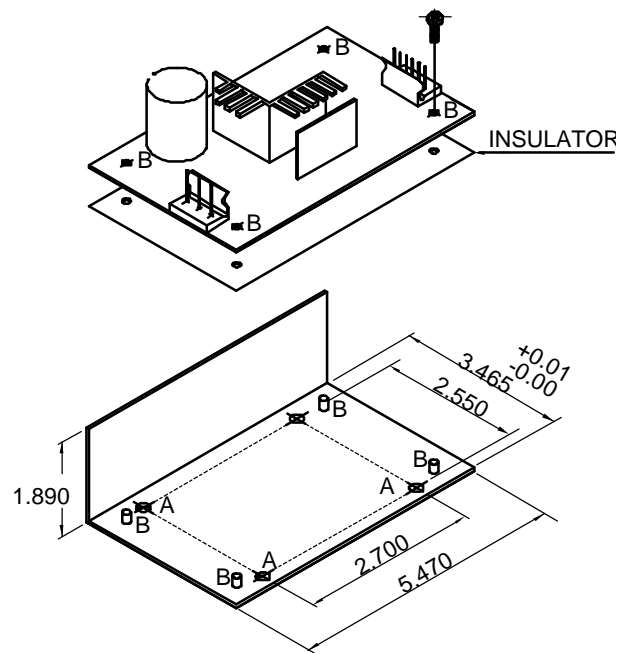

SMX POWER

3005 Avenida Simi, Simi Valley, CA 93063
TEL: (805) 582-2804 FAX: (805) 582-2308
<http://www.smxpower.com>

MECHANICAL OUTLINE DIMENSIONS
UNIT : INCH
GENERAL TOLERANCE : +/- 0.005
OVERALL SIZE :
L5.470X B3.465XH1.890